

# WORKLAB

## Technical information



# 10 year Warranty

See Warranty statement



# Technical information

## Configurations

- Mobile shelving unit with 4 fixed shelves and semi-open back (1)
- Mobile shelving unit with 2 fixed shelves, cabinet and semi-open back (2)
- Mobile shelving unit with 2 fixed shelves, cabinet and back panel (3)
- Mobile media wall with fixed shelf, cabinet and back panel (4)
- Mobile workstation with fixed cabinet and back panel (5)

1



2



3



4



5



## Metal frame

- Welded metal tube – 25x25 mm;
- Powder coated metal.

## Metal lower bases

- Metal tube – 50x25 mm;
- In all configurations the length is 590 mm, except for workstation with a desktop – the length is 650 mm;
- Powder coated metal.

## Footrest metal beam

- Only in the workstation configuration;
- Metal tube – Ø30 mm;
- Powder coated metal (double painting).

## Castors

- Four swivel castors, Ø100 mm;
- With wheel brakes;
- Rotates in all directions;
- Load capacity – 100 kg per castor;
- Make sure that before relocating a unit with castors, all electrical components are disconnected from the main power source and hanged on hook of the side panel or placed securely.

## Shelves

- 25 mm MFC (melamine) with 2 mm ABS edging;
- Load capacity – 25 kg.

## Lower cabinet

- Top, bottom, side and back panels are made of 25 mm MFC (melamine) with 2 mm ABS edging;
- Sliding doors are made of 16 mm MFC (melamine) with 1 mm ABS edging;
- Dimensions: 280x566, H=370 mm (inner, two sections).

## Desktop

- Only in the workstation configuration, order separately;
- 25 mm MFC (melamine) with 2 mm ABS edging;
- The corners of desktop are rounded – R80 mm;
- Scallop for cable management: 350x40 mm;
- Optional cut-out for a power socket integration.

## Fabric back panel

- Made of 16 mm chipboard;
- Covered with 3 mm foam;
- Upholstered with fabric.

## Fabric and whiteboard back panel

- Fabric side is made of 8 mm MDF covered with 3 mm foam;
- Upholstered with fabric;
- Whiteboard side is made of 12 mm chipboard pressed in HPL with 1 mm ABS edging.

## Perforated metal sheet back panel

- Perforated 1 mm metal sheet with a Ø8 mm hole;
- The back panel has three vertical sections with a bended central part (except a shelving unit configuration);
- Top and bottom welded with metal tube 20x20mm;
- The edges are welded with metal profile;
- Matches the colour of the frame;
- Powder coated metal.

## Accessories (optional)

### Fabric side panel (1, 2)

- With or without a metal hook for wire management;
- 8 mm MDF covered with 3 mm foam;
- Upholstered with fabric;
- Double-sided panel hides an inner metal construction;
- Metal brackets for mounting;
- Load capacity of metal hook - 3 kg;
- Powder coated metal.

### Perforated metal sheet side panel (3, 4)

- With or without a metal hook for wire management;
- Perforated 1 mm metal sheet with a Ø8 mm hole;
- Two edges are welded with metal profile;
- Fixed with screws;
- Load capacity of metal hook - 3 kg;
- Powder coated metal.

### Side shelf (5)

- Powder coated metal;
- Should be hanged only on the crossbars of the side frame;
- Fixed with screws;
- Load capacity - 10 kg per shelf.

### Hook (6)

- Powder coated metal;
- Should be hanged only on the crossbars of the side frame;
- Fixed with a screw;
- Load capacity - 5 kg per hook.

### Screen holder (7)

- Two types of holders: for perforated metal back and fabric back;
- Powder coated metal;
- VESA standard - 100x100 mm;
- Recommended screen weight is up to 15 kg;
- Screws for screen fixing to VESA plate are not included.

1



2



3

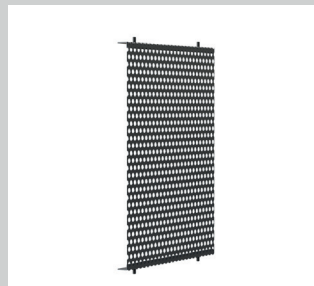

4

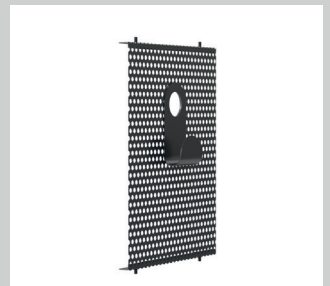

5



6



7



# Range

Mobile shelving unit  
with 4 fixed shelves and semi-open back

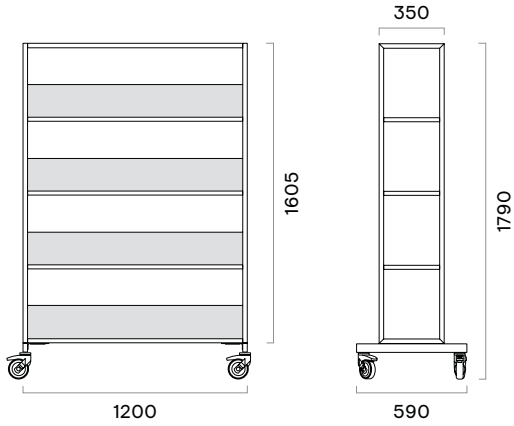

Mobile shelving unit  
with 2 fixed shelves, cabinet and semi-open back

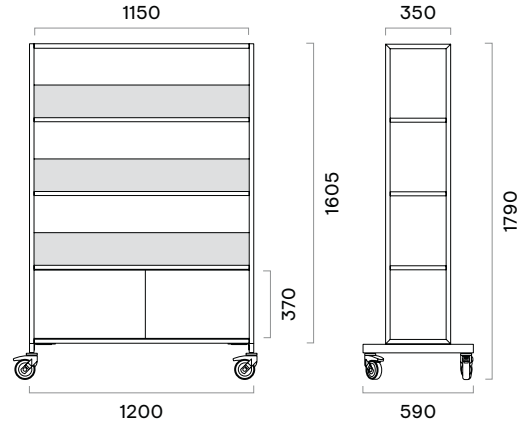

Mobile shelving unit  
with 2 fixed shelves, cabinet and back panel

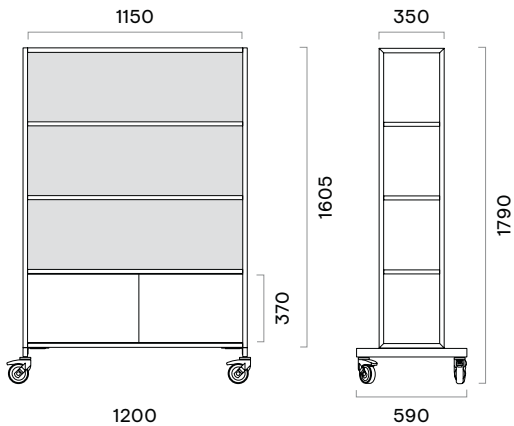

Mobile media wall  
with fixed shelf, cabinet and back panel

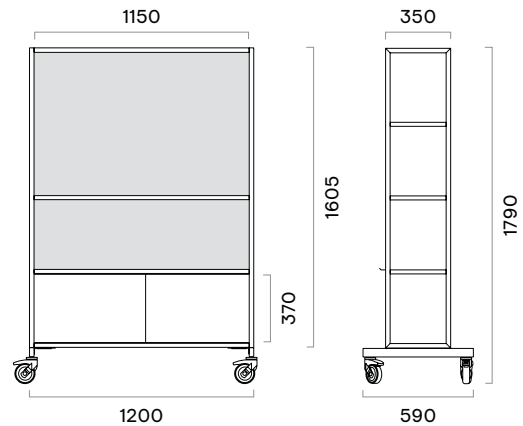

Mobile workstation  
with fixed cabinet and back panel

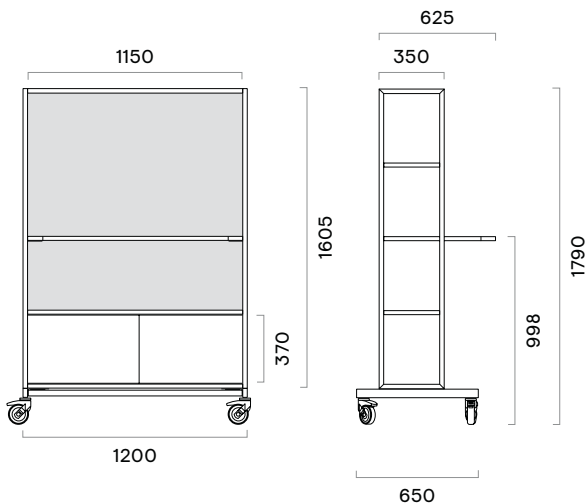

Desktop for a mobile workstation

with a scallop cut-out for wire management

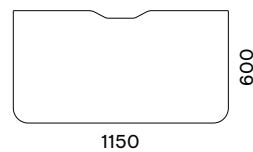

with a scallop cut-out for wire management and a cut-out for a power socket

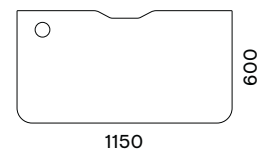

# Accessories

## Side panels

Perforated metal

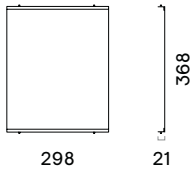

Fabric

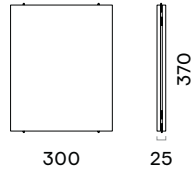

## Side panel with a hook for wire management

Perforated metal

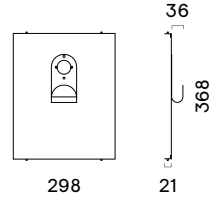

Fabric

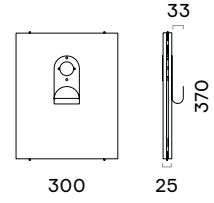

## Side shelf

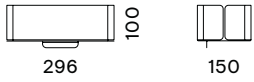

## Hook



## Screen holder

For the back side of perforated metal

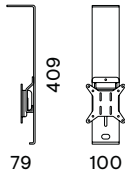

For the back side of fabric/melamine

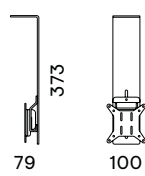



## Additional information

- Only one accessory (except hook) can be fixed in the space between two crossbars of the side frame. Two hooks can be placed on one crossbar.



- There are two mounting options for the screen: on the front side or on the back side.



- Convenient electrical solutions for wire management. See the example below.

